

Series V265-8.5

- (10 ~ 155)MHz
- 14 pin DIL resistance weld case
- sine wave, CMOS output
- wide pulling range
- good linearity

Applications:

- communications equipment
- instrumentation
- portable systems

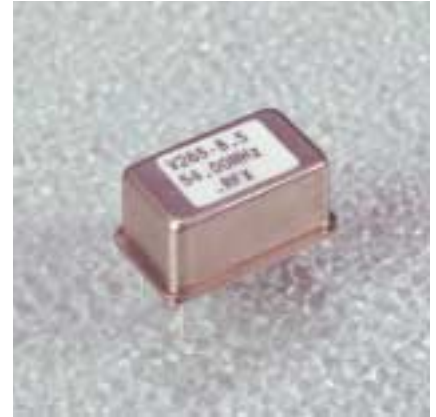

Standard options:

frequency range:	_____ (10 ~ 155)MHz _____		
accuracy codes:	_____ (A) _____	_____ (B) _____	
temperature tolerance	±10ppm	±20ppm	
temperature range	(0 +50)°C	(-20 +70)°C	
output codes:	_____ (S) _____	_____ (L) _____	
output	sine wave, 0dBm into 50Ω harmonics -30dBc max.	CMOS 15pF, 45% ~ 55% <2ns max. rise and fall	
supply voltage codes:	_____ (V1) _____	_____ (V2) _____	_____ (V3) _____
supply voltage	+3.3Vd.c.	+5.0Vd.c.	+12.0Vd.c.
control voltage V _c	(+1.5 ±1.5)Vd.c.	(+2.25 ±2.25)Vd.c.	(+2.25 ±2.25)Vd.c.
voltage control range	±100ppm max.*	±200ppm max.*	±300ppm max.*
	*control range is frequency dependent		

Generic specification:

stability:		
ageing long term		±2ppm max. first year
control range linearity		±10%
control voltage input impedance		100KΩ min.
power supplies:		
supply current		50mA typical
insulation resistance		500MegΩ min., 100Vd.c.
temperature:		
operating range	(0 +50)°C	(-20 +70)°C
storage range	(-40 +125)°C	(-40 +125)°C

Environmental conditions:

mechanical shock: MIL standard 202F, method 213, condition J

thermal shock: MIL standard 202F, method 107, condition A

vibration: MIL standard 202F, method 204, condition B

solderability: 5 seconds max. at +230°C, 3 seconds max. at +350°C

Marking:

frequency, date code, serial number on high temperature metalised polyester label

Ordering code:

standard options:

V265-8.5 A S V2 - 155.52M

V265-8.5 = series generic code

A temp. tol. and temp. range code: A = $\pm 10\text{ppm}(0 + 50)^\circ\text{C}$

S output code: S = sine wave output, 0dBm into 50Ω

V2 supply voltage code: V2 = +5Vd.c. supply

155.52M output frequency: 155.52M = 155.52MHz

custom specification: part number issued with custom specification and drawing

Dimensions(mm):

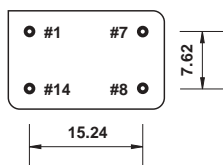
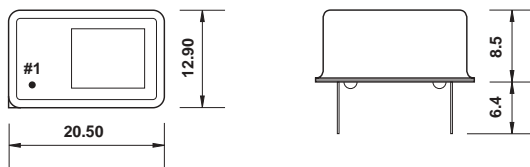

Pins viewed from bottom
pin diameter 0.45mm

Pin connections:

- #1 control voltage V_c
- #7 ground/case
- #8 output
- #14 + V_{cc}

Test circuit, CMOS load:

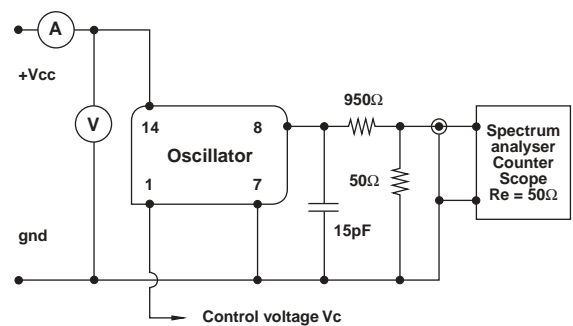

test circuit includes a 20:1 step down into a matched 50Ω load